



FAA PART 107 COMPLETE GUIDE 2026

What Every Commercial Drone Operator Needs to Know

Wesley Alexander | Senior Test Pilot & FAA Consultant, UAVHQ

The Foundation of the National Airspace System (NAS)

Pre-2016

Section 333 Exemptions

The “Wild West.”
Bureaucratic, slow, required
a traditional manned
manned pilot’s license.



2016

Part 107 Introduced

The “Small Unmanned
Aircraft Rule.” Democratized
commercial airspace,
replacing Section 333
exemptions.



2026 & Beyond

The Modern Framework

Safely integrates millions
of drones into the US NAS
with dynamic tracking,
remote ID, and automated
authorizations.



Pilot’s Note: If your flight furthers a business purpose in any way—even if no money changes hands—you are operating under Part 107.

Commercial Use Cases: Do You Need a License?



Media & Business

Real estate photography, film production, marketing, media coverage, and paid delivery services.



Industrial & Construction

Site monitoring, cell tower inspections, infrastructure assessments, and 3D mapping.



Agriculture & Environment

Crop health assessments, targeted spraying, surveying, and terrain modeling.



Public & Non-Profit

Educational institution research (beyond basic recreation), state/local government ops, and non-profit activities.

The 4 Pillars of Part 107 Compliance

● Status: Required

The Pilot



Must be 16+ years old.
English proficiency required (read, write, speak).
Physically and mentally fit to safely operate.

● Status: Required

The Test



Must pass the Initial Aeronautical Knowledge Test at an FAA-approved center (minimum score: 70%).
Subject to TSA background vetting.

● Status: Required

The Aircraft



Maximum weight: under 55 lbs (including payload). If over 250g (0.55 lbs), mandatory FAA registration.
Registration costs \$5 and is valid for 3 years.

● Status: Required

The Tech



Remote ID is now absolutely mandatory for all commercial operations within the National Airspace System.

Your Flight Path to Certification

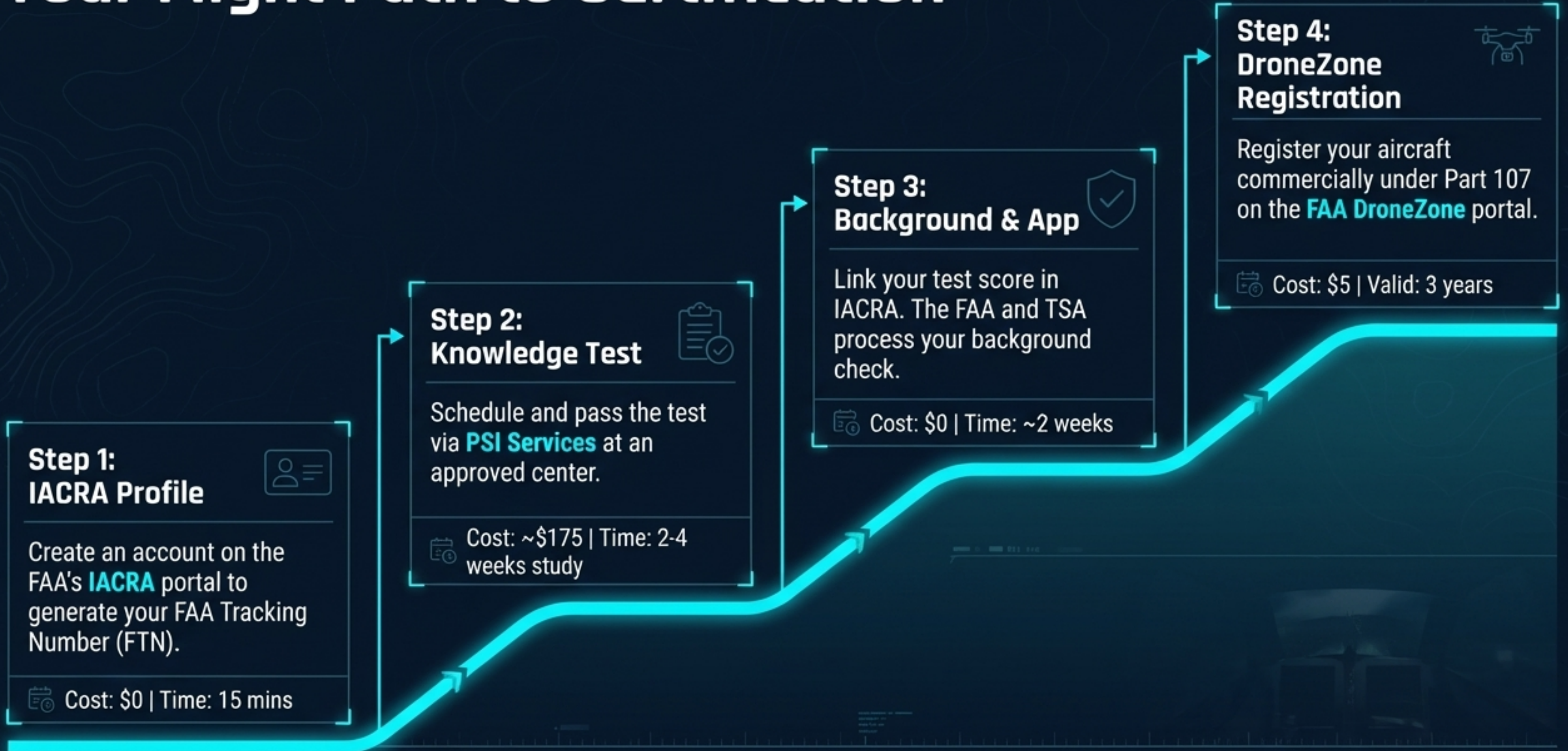

Anatomy of the Aeronautical Knowledge Test

Flight Operations
(incl. Radio/Crew Mgmt):
13-18%

Regulations:
15-25%

Loading &
Performance:
7-11%

Weather &
Micrometeorology:
11-16%

Airspace &
Requirements:
15-25%



Test Pilot Insight

Don't memorize—understand.

Prioritize Airspace and Weather.

You will see sectional charts on the exam; you must know how to read Class B, C, and D airspace boundaries instinctively.

Standard Flight Envelope (Without Waivers)



Flight Parameters

1

Visibility: Minimum 3 statute miles. **VLOS** (Visual Line of Sight) mandatory at all times.

2

Time of Day: Daylight operations standard. Twilight allowed only with **3SM anti-collision lights**.

Prohibited Limits



No flying over non-participating people.
No flying from a moving vehicle (except sparsely populated areas).
No carrying hazardous materials or dropping objects.

Emergency Squawk Box



Accidents causing serious injury, loss of consciousness, or >\$500 in property damage **MUST** be reported to the FAA within 10 days.

Remote ID Compliance: The 'Digital License Plate'

Real-time broadcasting of drone identification and location to secure the NAS.

Option A: Built-In Standard Remote ID



- Native to newer enterprise and prosumer drones.
- Broadcasts directly from the drone's native firmware.

 **Telemetry:** Tracks and broadcasts exact operator location dynamically via the controller.

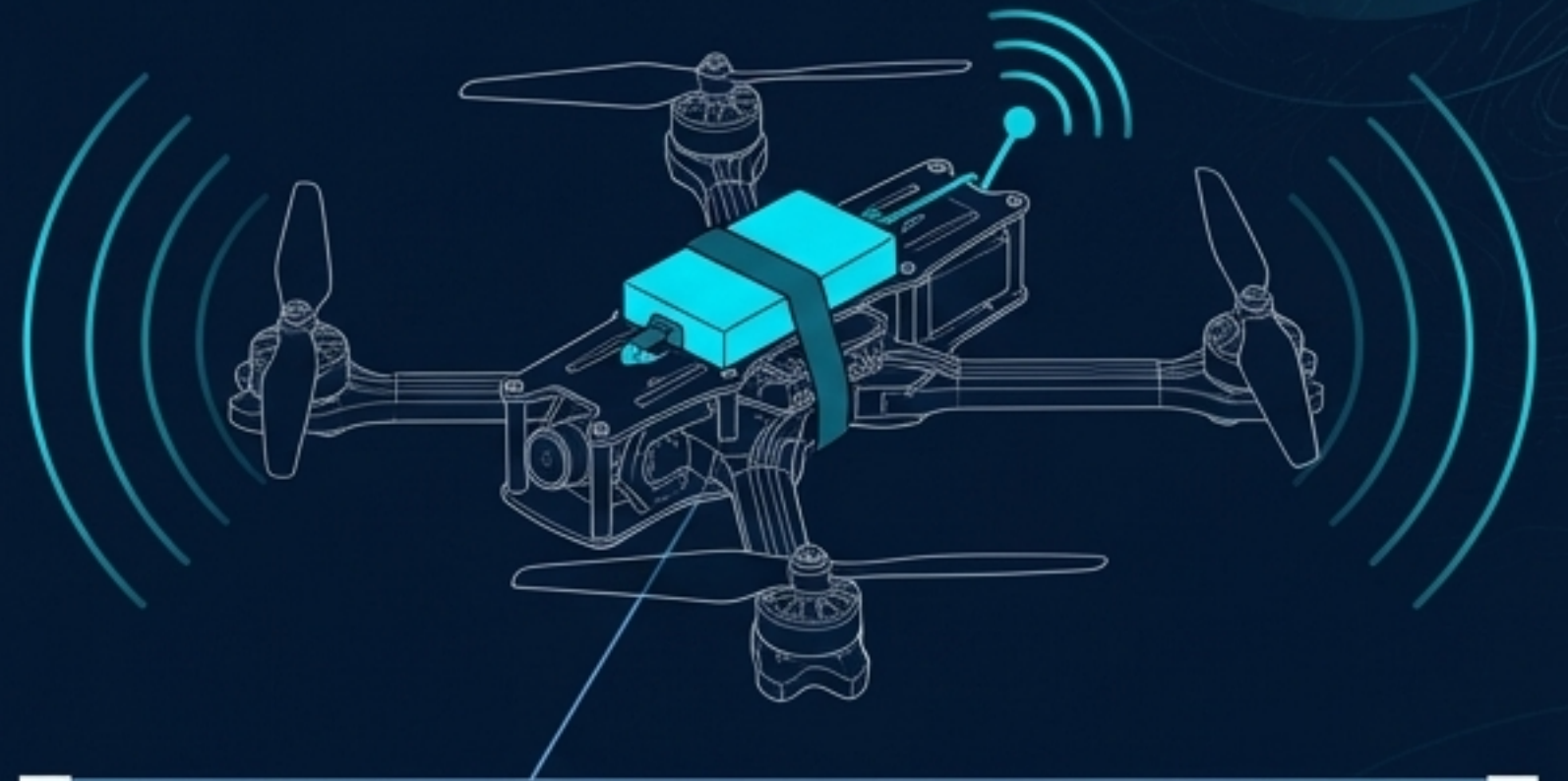

Option B: Broadcast Module

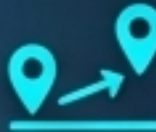

- Retro-fitted solution for older, legacy fleets.
- Physical, battery-powered module attached to the airframe.

 **Telemetry:** Broadcasts the drone's takeoff location rather than dynamic pilot location.

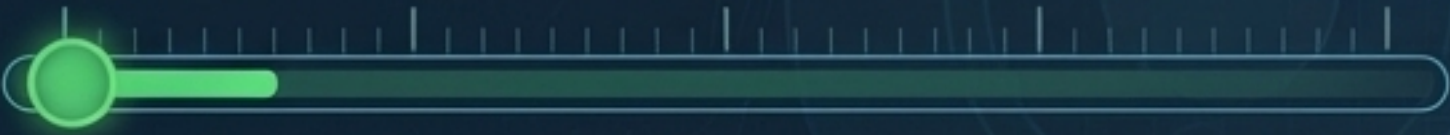
Part 107 Waivers & Authorizations

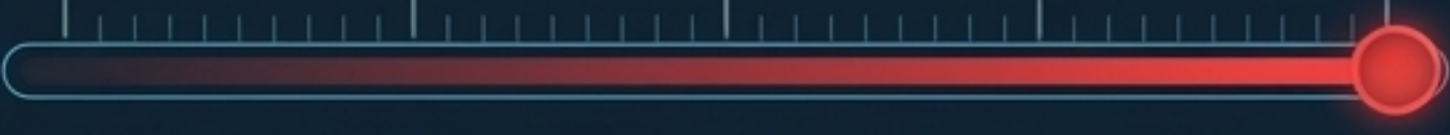
Controlled Airspace (LAANC)	Operating in Class B/C/D/E surface areas. Over 700 airports supported.	 Reality Check: Automated, approved in minutes.
107.29 Night Ops	Requires specific anti-collision lighting (visible 3SM) and specialized pilot training.	 Reality Check: Streamlined if pilot is properly trained.
107.39 Over People	Strict categorical limits based on aircraft kinetic energy and required blade guards.	 Reality Check: Difficult; requires a robust safety case.
107.31 BVLOS	(Beyond Visual Line of Sight). Requires advanced detect-and-avoid tech.	 Reality Check: 90-120 days minimum. High rejection rate without expert drafting.

Proceed to Launch: Operator Resources

Establish Identity >>

Visit [IACRA.faa.gov](https://iacra.faa.gov) to create your profile and get your FTN.

Book Your Test >>

Navigate to [PSI Exams](#) to schedule your initial aeronautical knowledge test.

Register Your Fleet >>

Go to [FAADroneZone.faa.gov](https://faadronezone.faa.gov) to register commercial aircraft and process standard waivers.

Maintain Currency >>

Use [FAA WINGS](#) for free recurrent training to keep your certification active.

Expert Navigation >>

Need help drafting a BVLOS waiver or building an enterprise fleet program? [Consult UAVHQ](#).